

SECTION **EX**
EXHAUST SYSTEM

A
EX
C
D
E
F
G
H
I
J
K
L
M
N
O
P

CONTENTS

PRECAUTION	2	Commercial Service Tool	3
PRECAUTIONS	2	PERIODIC MAINTENANCE	4
Precaution for Supplemental Restraint System (SRS) "AIR BAG" and "SEAT BELT PRE-TEN- SIONER"	2	EXHAUST SYSTEM	4
PREPARATION	3	Inspection	4
PREPARATION	3	REMOVAL AND INSTALLATION	5
Special Service Tool	3	EXHAUST SYSTEM	5
		Exploded View	5

PRECAUTIONS

< PRECAUTION >

PRECAUTION

PRECAUTIONS

Precaution for Supplemental Restraint System (SRS) "AIR BAG" and "SEAT BELT PRE-TENSIONER"

INFOID:000000009486633

The Supplemental Restraint System such as "AIR BAG" and "SEAT BELT PRE-TENSIONER", used along with a front seat belt, helps to reduce the risk or severity of injury to the driver and front passenger for certain types of collision. Information necessary to service the system safely is included in the SR and SB section of this Service Manual.

WARNING:

- To avoid rendering the SRS inoperative, which could increase the risk of personal injury or death in the event of a collision which would result in air bag inflation, all maintenance must be performed by an authorized NISSAN/INFINITI dealer.
- Improper maintenance, including incorrect removal and installation of the SRS, can lead to personal injury caused by unintentional activation of the system. For removal of Spiral Cable and Air Bag Module, see the SR section.
- Do not use electrical test equipment on any circuit related to the SRS unless instructed to in this Service Manual. SRS wiring harnesses can be identified by yellow and/or orange harnesses or harness connectors.

PRECAUTIONS WHEN USING POWER TOOLS (AIR OR ELECTRIC) AND HAMMERS

WARNING:

- When working near the Airbag Diagnosis Sensor Unit or other Airbag System sensors with the Ignition ON or engine running, DO NOT use air or electric power tools or strike near the sensor(s) with a hammer. Heavy vibration could activate the sensor(s) and deploy the air bag(s), possibly causing serious injury.
- When using air or electric power tools or hammers, always switch the Ignition OFF, disconnect the battery and wait at least three minutes before performing any service.

PREPARATION

< PREPARATION >

PREPARATION

PREPARATION

Special Service Tool

INFOID:000000009405627

A

EX

The actual shapes of Kent-Moore tools may differ from those of special service tools illustrated here.

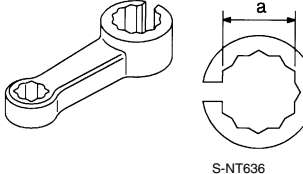
Tool number (Kent-Moore No.) Tool name	Description
KV10114400 (J-38365-N1) Heated oxygen sensor wrench 	Loosening or tightening heated oxygen sensors: a: 22 mm (0.87 in)



C

D

E

Commercial Service Tool

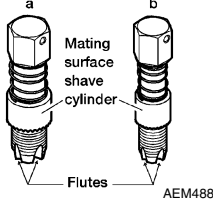
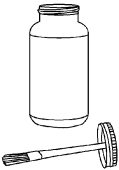
INFOID:000000009405628

(Kent-Moore No.) Tool name	Description
(J-43897-18) (J-43897-12) Oxygen sensor thread cleaner 	Reconditioning the exhaust system threads before installing a new oxygen sensor (Use with anti-seize lubricant shown below): a: J-43897-18 (18 mm dia.) for zirconia oxygen sensor b: J-43897-12 (12 mm dia.) for titania oxygen sensor
Anti-seize lubricant (Permatex 133AR or equivalent meeting MIL specification MIL-A-907) 	Lubricating oxygen sensor thread cleaning tool when reconditioning exhaust system threads
Power tool 	Loosening nuts, screws and bolts

F

G

H

I

J

K

L

M

N

O

P

EXHAUST SYSTEM

< PERIODIC MAINTENANCE >

PERIODIC MAINTENANCE

EXHAUST SYSTEM

Inspection

INFOID:000000009405629

Check exhaust pipes, muffler, and mounting for improper attachment, leaks, cracks, damage or deterioration.

- If anything is found, repair or replace damaged parts.

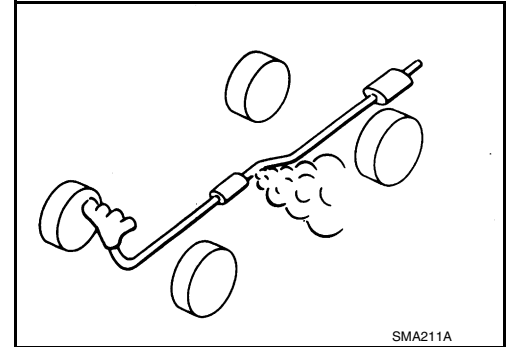

SMA211A

EXHAUST SYSTEM

< REMOVAL AND INSTALLATION >

REMOVAL AND INSTALLATION

EXHAUST SYSTEM

Exploded View

INFOID:000000008969011

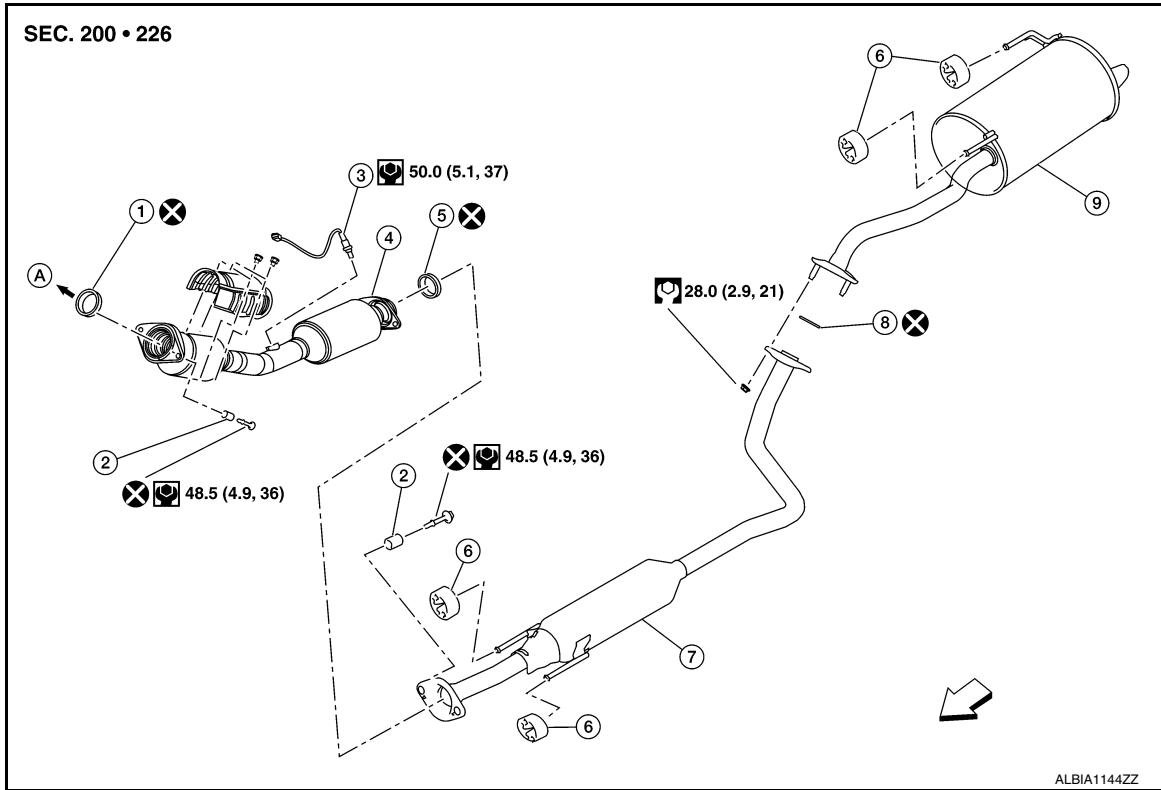

- | | | |
|------------------------|-----------------|---------------------------|
| 1. Seal bearing | 2. Spring | 3. Heated oxygen sensor 2 |
| 4. Front Exhaust tube | 5. Seal bearing | 6. Mounting rubber |
| 7. Center muffler | 8. Ring gasket | 9. Main muffler |
| A. To Exhaust manifold | | |

WARNING:

- Perform the procedures with the exhaust system fully cooled down to avoid injury from the hot exhaust system.
- Be careful not to cut your hand on the insulator edge.

CAUTION:

Use genuine NISSAN exhaust system parts or equivalent, which are specifically designed for heat resistance, corrosion resistance, and shape.

REMOVAL

- Disconnect each joint and mounting.
- Remove heated oxygen sensor 2 (1) using Tool (A).

Tool number : KV10114400 (J-38365-N1)

← : Front

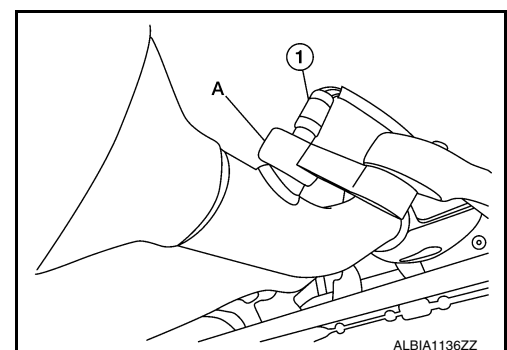

ALBIA1136ZZ

EXHAUST SYSTEM

< REMOVAL AND INSTALLATION >

INSTALLATION

CAUTION:

- Do not reuse gasket.
- Do not reuse seal bearing.
- Discard any heated oxygen sensor 2 which has been dropped from a height of more than 0.5 m (19.7 in) onto a hard surface such as a concrete floor. Use a new one.
- Before installing a new heated oxygen sensor 2, clean exhaust system threads using a suitable tool and apply anti-seize lubricant.

Oxygen sensor thread cleaner : J-43897-12

Oxygen sensor thread cleaner : J-43897-18

- Do not over tighten heated oxygen sensor 2. Doing so may cause damage to the heated oxygen sensor 2, resulting in the “MIL” coming on.
- Prevent rust preventives from adhering to the sensor body.
- If heat insulator is badly deformed, repair or replace it. If deposits such as mud pile up on the heat insulator, remove them.
- When installing heat insulator avoid large gaps or interference between heat insulator and each exhaust pipe.
- Remove deposits from the sealing surface of each connection. Connect them securely to avoid exhaust gas leaks.
- When installing each mounting rubber, use silicon oil to avoid twisting.
- Temporarily tighten nuts and bolts. Check each part for unusual interference and mounting rubber interference, and then tighten them to the specified torque.
- When installing each mounting rubber, avoid twisting or unusual extension in up/down, front/rear and right/left directions.

Exhaust Manifold to Exhaust Front Tube

1. Place a piece of wood (A) on seal bearing (2) and securely insert the seal bearing on the exhaust manifold (1) side, using a plastic hammer (B).

CAUTION:

- Do not damage the seal bearing surface during insertion.
- If seal bearing is inserted by hammering directly without using a piece of wood, the seal bearing is deformed and exhaust gas leaks. To insert seal bearing, always use a piece of wood and insert straight.

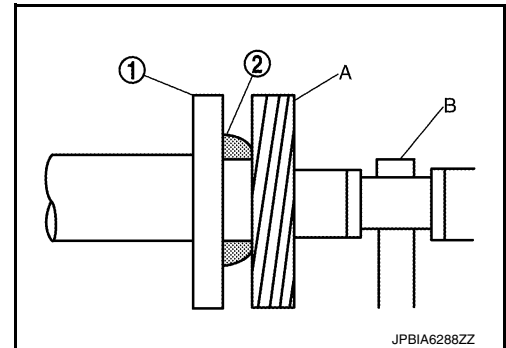

2. Check that seal bearing (1) is in absolute contact (C) with the flange (A). If there is clearance (B), insert seal bearing straight by hand to bring the seal bearing into absolute contact with the flange.

CAUTION:

- Do not use a tool for insertion.
- Do not insert seal bearing by tightening exhaust front tube.

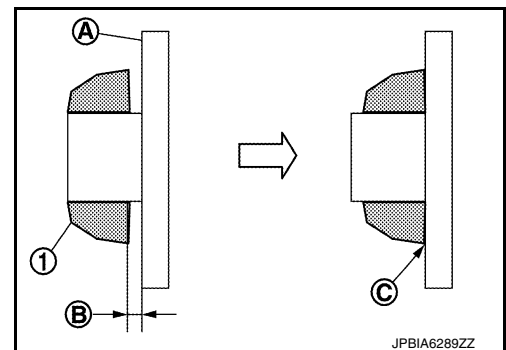

EXHAUST SYSTEM

< REMOVAL AND INSTALLATION >

3. With spring (3), tighten nut (4).

CAUTION:

- Ensure springs are seated correctly on the flange and not sitting on locator dimple (A).
- Be careful that stud bolt does not interfere with mounting hole of exhaust front tube (←).

- (1) : Spring
(2) : Seal bearing
(5) : Bolt
(6) : Front exhaust tube

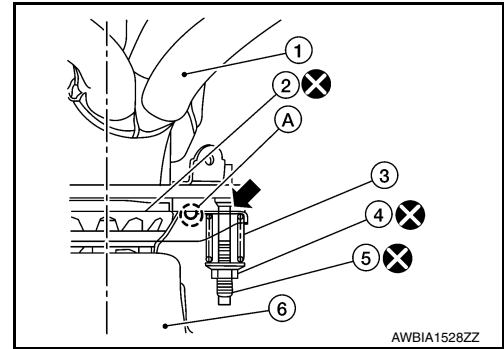

4. After installing, check that bolt does not interfere with mounting hole of exhaust front tube.

Exhaust Front Tube to Center Muffler

1. Securely insert seal bearing (2) into exhaust front tube (1).

- (3) : Spring
(4) : Bolt
(5) : Center muffler

CAUTION:

Be careful not to damage seal bearing surface when installing.

2. With spring, tighten bolt.

CAUTION:

- Ensure springs are seated correctly on the flange and not sitting on locator dimple (A).
- Be careful that bolt does not interfere with mounting hole of center muffler.

3. After installing, check that bolt does not interfere with mounting hole of center muffler.

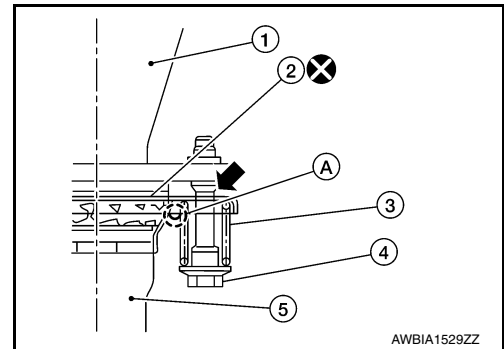

INSPECTION AFTER INSTALLATION

- With the engine running, check the exhaust tube joints for exhaust gas leaks and unusual noises.
- Check that the mounting brackets and mounting insulators are installed properly and free from excessive stress. Improper installation could result in excessive noise, leaks, and vibration.